

(No Model.)

A. SEQUEIRA.
CENTERING GAGE.

No. 271,746.

Patented Feb. 6, 1883.

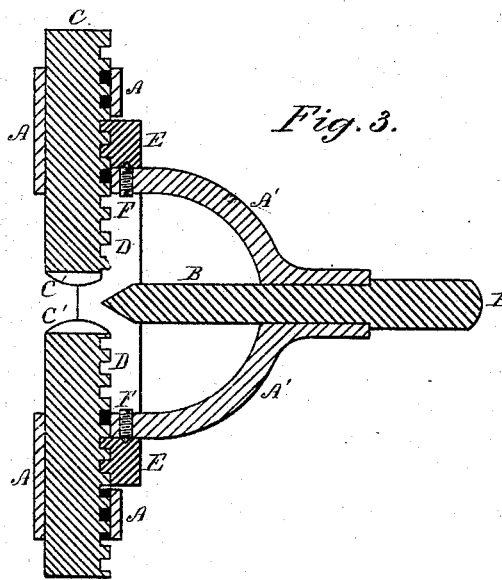
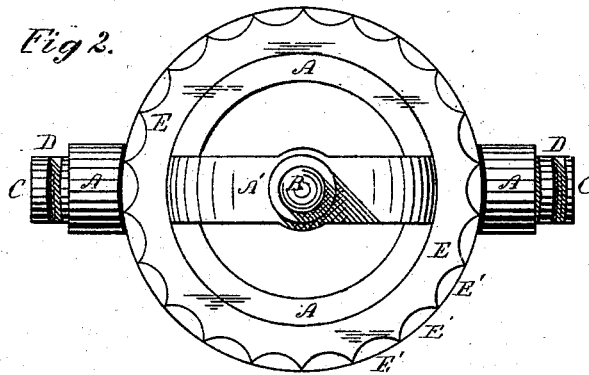
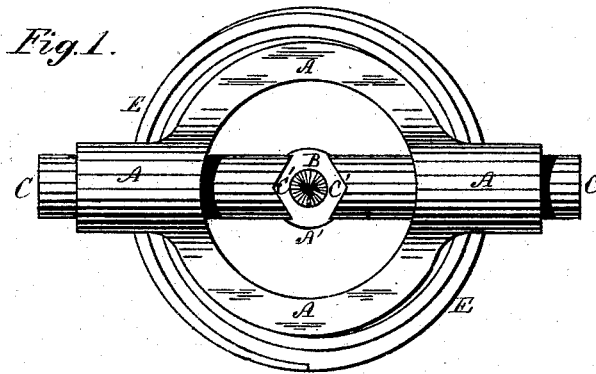

Witnesses.

David T. Dimock.
C. S. Burdett.

Inventor.

Augustus Sequeira
by Theo. G. Ellis,
Att'y.

UNITED STATES PATENT OFFICE.

AUGUSTUS SEQUEIRA, OF HARTFORD, CONNECTICUT.

CENTERING-GAGE.

SPECIFICATION forming part of Letters Patent No. 271,746, dated February 6, 1883.

Application filed October 16, 1882. (No model.)

To all whom it may concern:

Be it known that I, AUGUSTUS SEQUEIRA, of Hartford, in the county of Hartford and State of Connecticut, have invented certain
5 new and useful Improvements in Centering-Gages; and I do hereby declare that the following is a full, clear, and exact description thereof, whereby a person skilled in the art can make and use the same, reference being
10 had to the accompanying drawings, and to the letters of reference marked thereon.

Like letters in the figures indicate the same parts.

My improvement relates to gages for marking
15 a center-point in the end of bars of metal or other objects for drilling the center-holes upon which such articles are turned in a lathe or supported in any other machine.

The object of my invention is to provide a
20 simple and inexpensive tool which shall be adapted to fixing the centers upon bars of different forms and sizes.

In the accompanying drawings, illustrating my invention, Figure 1 shows a front view of
25 my improved centering-gage. Fig. 2 shows a rear view of the same. Fig. 3 is a longitudinal section through the middle of the gage, showing more particularly its internal construction.

A is the fixed body of the gage. It is provided with the bow A' on the rear side, through
30 which is bored a cylindrical slot in which the center-punch slides back and forth at right angles to the face of the gage.

B is the center-punch, which has a shank
35 fitting exactly in the socket in A', and which is provided with a conical point in the customary manner. The outer end of the punch is made a little larger than the shank, so that it will not pass through the socket. This part
40 is generally milled or roughened for convenience in handling.

C C are jaws for grasping and fixing the
45 position of the object to be centered. They slide out and in radially through sockets in the frame or body A. They are intended to be of a cylindrical form, as shown in the drawings, and are provided at their inner ends with angular openings C', for embracing the
50 object to be centered. The rear sides of these jaws are cut into racks D D, by means of which the jaws are moved and held firmly in position.

E is the ring, which fits upon a circular bear-

ing on the frame A, just back of the jaws C. This ring is furnished on its face with a scroll
55 or spiral, which fits into the teeth of the racks upon the jaws in such a manner that when the ring is turned around on its bearing the jaws are forced in or out. The scroll enters the
60 racks on the jaws in such a position that the inner ends of the jaws are exactly equidistant from the axis of the center-punch B.

F F are two conical-ended screws, which
65 pass through the frame A and enter a groove in the ring E to hold it in place upon its bearing, while permitting it to turn freely around. The ring E is furnished with a series of indentations or milling, E', around its outer edge
70 to enable it to be turned readily by hand.

The operation of my invention is as follows:
75 When the ring E is turned the scroll on its face acts upon the racks on the jaws C and moves them simultaneously out or in a radial direction, so that the bearings on the inner
80 ends are always exactly the same distance from the center. When it is desired to center any object it is placed between the jaws and the ring E turned to bring the jaws together, so as to touch at opposite points.
85 The center-punch is then struck by a mallet or hammer to make a mark upon the end of the bar or other object held. This gives the point for the hole to be drilled in the customary manner. My improved gage is adapted
90 to mark the center-point upon bars of various shapes as well as sizes. A round bar is embraced by the wyes on the inner ends of the jaws. A square or rectangular bar is embraced by two corners at opposite ends of a
95 diagonal. A polygonal bar is embraced by two opposite angles. This result is obtained by having only two jaws, and causing them to be provided with wyes at their inner ends and to move simultaneously in opposite directions in the same straight line, with their inner ends
at the same exact distance from the center.

What I claim as my invention is—

A centering-gage composed of the frame A, the two sliding jaws C C, furnished with racks D, the scroll-ring E, gearing into said racks
100 and turning on the frame A, and the center-punch B, substantially as described.

AUGUSTUS SEQUEIRA.

Witnesses:

THEO. G. ELLIS,

EDWIN F. DIMOCK.